

PowerTech™

4045TFM50 Diesel Engine

Marine Generator Drive Engine Specifications

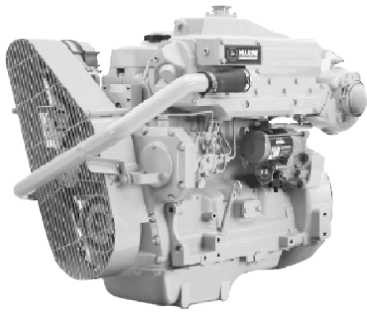

4045TFM50 shown

Dimensions

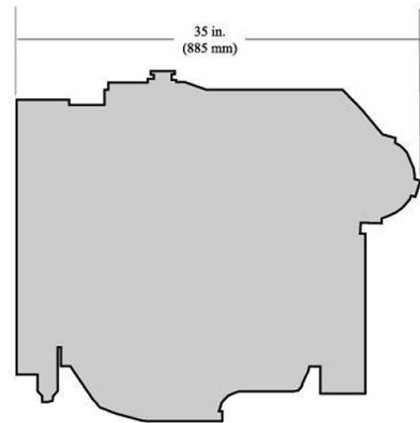
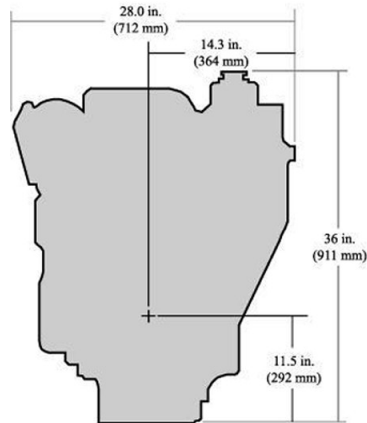

Certifications

none

General data

Model	4045TFM50	Length - mm (in)	885 (34.8)
Number of cylinders	4	Width - mm (in)	713 (28.1)
Displacement - L (cu in)	4.5 (275)	Height-- mm (in)	911 (35.9)
Bore and Stroke-- mm (in)	106 x 127 (4.17 x 5.00)	Weight, dry-- kg (lb)	462 (1019)
Compression Ratio	17.2:1	Maximum Installed Angle	Front Up – degrees 12 Front Down – degrees 0
Engine Type	In-line, 4- Cycle		
Aspiration	Turbocharged		

Features and benefits

Watercooled Turbocharger and Exhaust Manifold

- Cooler and quieter environment for vessel and crew
- Reduced external connections eliminates hoses and fittings that can leak or break

Replaceable Wet-type Cylinder Liners

- Excellent heat dissipation
- Hardened and precision machined for long life
- Rebuild to original specifications

Internal Balancers

- Low noise and vibration for crew comfort

Corrosion Resistant Components

- Provides engine protection from the effects of seawater

Either-side Service

- Oil fill and dipstick combinations
- Remote oil filter for easier service access
- Application and service flexibility to provide installation convenience plus fast and easy maintenance

Fuel System

- Proven and reliable Mechanical Governor

Heat exchanger or Keel Cooled

- High-capacity heat exchanger designed for reliable operation in adverse conditions
- Integrated expansion tank, heat exchanger and exhaust manifold reduce chances of leaks
- Keel cooler or heat exchanger options provide application flexibility

High Torque and Low Rated RPM

- Enables the engine to turn larger propellers at lower speed for best efficiency
- Excellent vessel control and maneuvering
- Lower rated rpm limits vibration and noise for better crew comfort

Performance curve

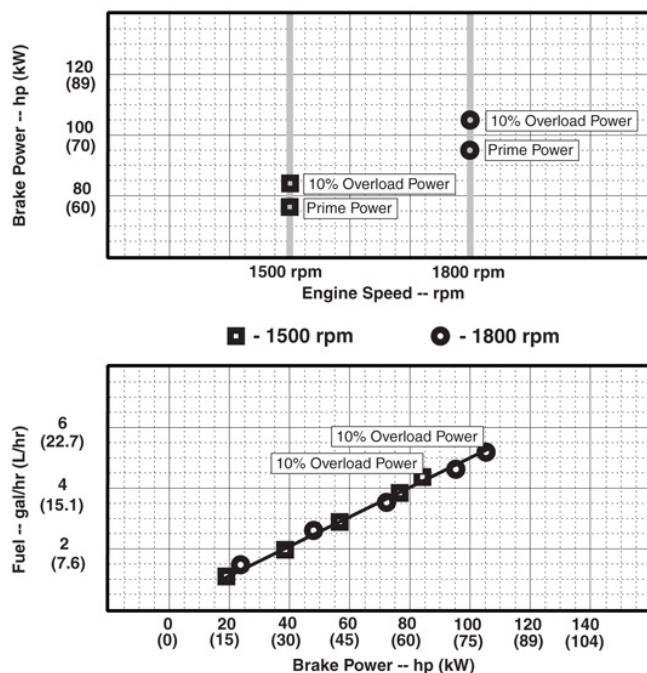

System data	1800 rpm	1500 rpm
Air system		
Engine air flow - m ³ /min (ft ³ /min)	5 (176.6)	4 (141.3)
Exhaust system		
Dry - mm (in)	50 (2.0)	50 (2.0)
Wet - mm (in)	63 (2.5)	63 (2.5)
Cooling system		
Coolant flow - L/min (gal/min)	125 (33.0)	116 (30.6)
Sea water system		
Pump flow - L/min (gal/min)	83 (21.9)	68 (18.0)
Fuel system		
Governor type	Mechanical	Mechanical
Governor regulation - %	5	5
Total fuel flow - L/hr (gal/hr)	113 (29.9)	109 (28.8)

Performance data	1800 rpm	1500 rpm
10% overload engine Power - kW (hp)	78 (104.6)	63 (84.5)
Prime engine power - kW (hp)	71 (95.2)	57 (76.4)
Low idle speed - rpm	1000	1000
BMEP - kPa (psi)	1054 (153)	1015 (147)

Performance data

Hz (rpm)	Generator efficiency %	Keel cooled		Power factor	Calculated gen-set rating	
		(no fan)			kW	kVA
50 (1500)	88-92	--	--	0.8	50-52	62-65
60 (1800)	88-92	--	--	0.8	62-65	78-81

John Deere Power Systems
3801 W. Ridgeway Ave.
PO Box 5100
Waterloo, IA 50704-5100
Phone: 1-800-533-6446
Fax: 319.292.5075

John Deere Power Systems
Usine de Saran
La Foulonnerie - B.P. 11.13
45401 Fleury les Aubrais Cedex
France
Phone: 33.2.38.82.61.19
Fax: 33.2.38.82.60.00

All values at rated speed and power with standard options unless otherwise noted. Specifications and design subject to change without notice.